

UTILITY REQUIREMENTS

(EX) — EXHAUST - (2) @ 8' x 12', 500 CFM @ .50 S.P., EACH

APPROVED _____

PRINT NAME:
DATE:
SIGNATURE:

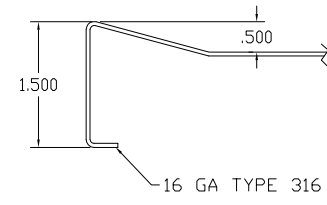

SECTION A-A

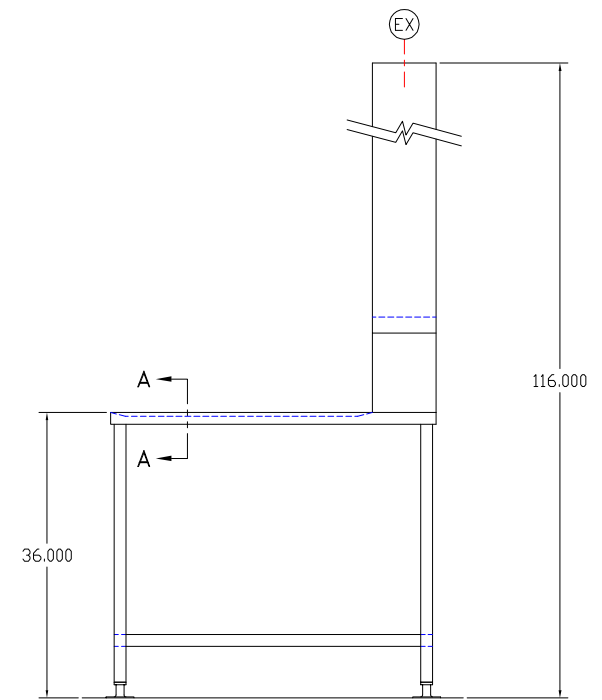
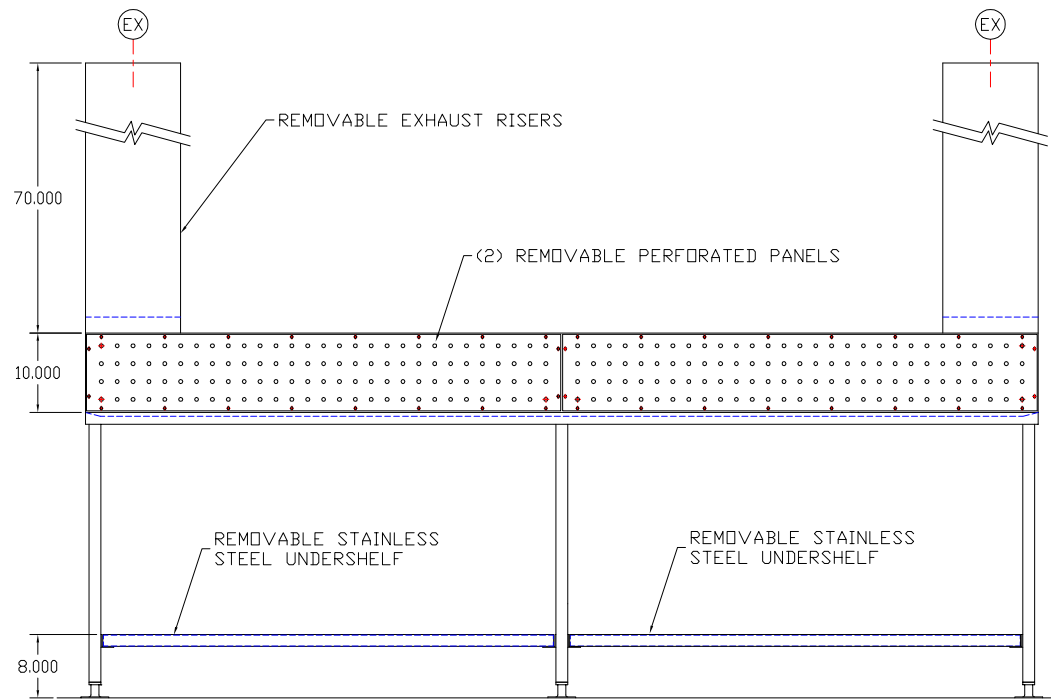

This print is the property of TBJ Incorporated. The information contained herein is confidential, it is not transferable. It is furnished with the clear understanding that it is not to be traced, reproduced or used in any other process of manufacturing without written permission from the owner and is returnable upon request.

LET		REVISION	BY	DATE		SCALE NTS REF DWG - R97058	DRAWN BY BSC DATE 8-6-02	1671 ORCHARD DRIVE CHAMBERSBURG, PA 17201
						41-120 BACKDRAFT TABLE		ROUGH-IN ASSY