

TBJ Model BD-2000 Bedding Dispenser (ref. dwg. R00043)

Description:

The TBJ Model BD-2000 Bedding Dispenser is designed for the precise, high speed filling of rodent cages with fresh, free flowing type-bedding material. Twin dispensing chutes provide simultaneous filling of two cages at a time. The operator simply pushes the cages against the trip lever switch to trigger the timed release of bedding material. An adjustable timer located on the control panel permits the operator to regulate the amount of bedding that is dispensed by setting the period of time that the dispensing chutes remain open. The timer may be programmed in seconds or tenths of seconds.

The total capacity of the BD-2000 is approximately 16 Cubic feet of chip-type, free flowing bedding material. The lower hopper will hold approximately 4 cubic feet and the upper hopper will hold approximately 12 cubic feet.

During operation, the diminishing level of bedding material in the upper hopper is automatically replenished from the waiting supply held in the lower hopper. This is accomplished by means of a photoelectrical controlled, screw-type conveying system.

Dust created during operation or loading is effectively controlled by an internal dust filtration system. The dust filtration system includes (2) blowers with (2) removable, washable filters. Two amber indicator lights indicate that the blowers are in operation during the dispensing process.

Overall dimensions of the BD-2000 are 92"H x 40" W x 31 1/2"D. The maximum cage height is 12". The electrical requirements are: 115V, 60 HZ, 1 PH, 15 AMP. Compressed air requirements are: 1/4" NPT, 15 PSI minimum.

Standard Design and Construction:

A. Structure: All structural support is stainless steel. All sprockets, shafts, chains, etc. are carbon steel.

B. Hoppers: Both the lower storage bin and the upper storage bin are 14 gauge type 304 stainless steel. Total hopper capacity is a minimum of 15 cubic feet. Upper dispensing hopper is equipped with a removable cover for cleaning or maintenance.

C. Bedding Transfer System: Bedding is transferred from the lower storage bin to the upper dispensing hopper by a continuous shovel type screw conveyor. The transfer system operates automatically and is equipped with an on-off toggle switch on the control panel.

D: Work Surface: The work surface consists of a stainless steel 3/8 inch diameter welded rod grid. The grid is designed to permit the dumping of bagged bedding through the grid to the storage bin. The grid provides a work surface for the operator and allows spillage to fall through to be automatically returned to the dispensing hopper above. The grid is easily removable for cleaning or maintenance.

E. Dust Filtration: The unit is equipped with (2) blowers and (2) removable filters to capture and contain dust generated in the dispensing compartment. The filter is washable and reusable.

F. Controls: The operator's control panel contains a main power On/Off selector switch, a Conveyor On/Off switch to control power to screw conveyor, a 0-10 second automatic reset timer for precise metering and distribution of bedding and (2) amber indicator lights to indicate that the dust filtration blower are in the operational mode. The timer automatically resets itself after completion of a dispensing cycle.

G. An operation manual and parts list shall be supplied with the unit.

Options and Accessories:

(consult options brochure for more detailed information)

- **Air Compressor:** The dispenser can be provided with an internal compressor to supply the air required for the bedding release valve. The compressor is pre-wired and pre-piped for automatic operation.

- **High Efficiency "Torit" Model 84 Cabinet Type Dust Collector System with 3 HP centrifugal blower rated @ 875 CFM @ 6" external static pressure in lieu of standard dust control package.** Unit to be provided with permanent type cotton sateen filter bags, a manual filter shaker, a 2 cu. ft. dust storage drawer and an exhaust silencer. The addition of this equipment increases the overall dimensions of the standard unit to 68" wide x 34-1/2" deep x 94" high. This unit must be factory installed. Voltage requirements change to 230V., 60 Hz. (Specify on-site voltage availability when ordering.)

- **Seismic restraints:** Seismic anchoring tie down package per California Administrative Code zone 4 can be provided.

NOTES: 1) MAXIMUM OVERALL DIMENSIONS MUST BE CONSIDERED FOR BUILDING ENTRY.
 2) ALL SEISMIC ANCHORING AND ANALYSIS IS BY OTHER.

TBJ Model BD-2000 Bedding Dispenser (ref. dwg. R00043)

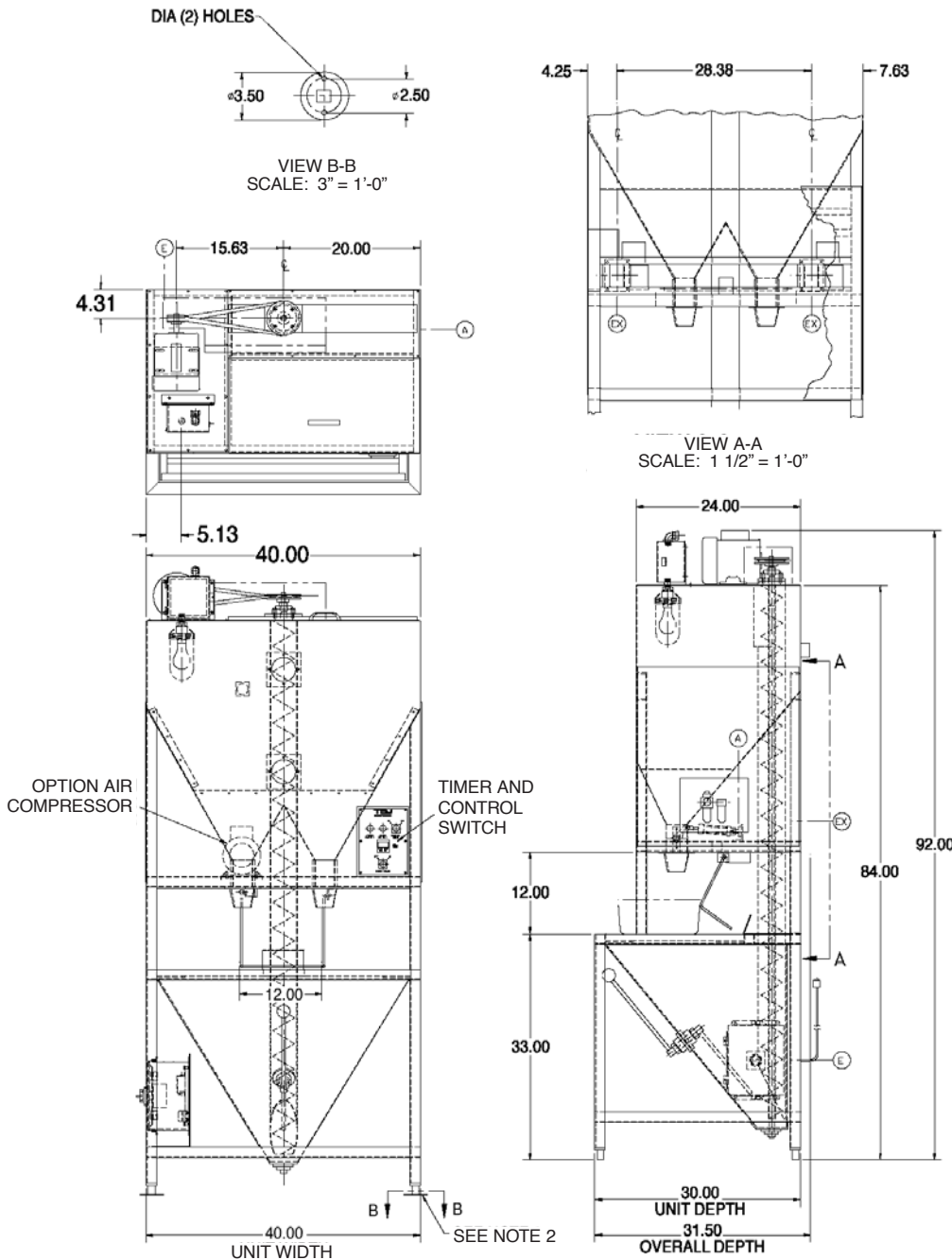

This print is the property of TBJ Incorporated. The information contained herein is confidential, it is not transferable. It is furnished with the clear understanding that it is not to be traced, reproduced or used in any process of manufacturing without written permission from the owner and is returnable upon request. Any infringement upon the patent rights shown herein, whether in whole or part, will be severely prosecuted.

Warranty

All components are warranted to be free from defects in material and workmanship for a period of one (1) year, when used in accordance with manufacturer's instructions.

Specification and drawing are subject to change without notice unless certified by factory.

Utility Requirements

- E --- Electrical - 115 V., 1 PH., 60 HZ., 15 AMP., 1/3 Hp.
- A --- Compressed Air - 1/4" N.P.T., 15 PSI Min., .1 CFM

TBJ
INCORPORATED

1671 Orchard Drive
 Chambersburg, PA 17201
 Phone: (717) 261-9700
 Fax: (717) 261-1730
 Email: sales@tjinc.com
 www.tjinc.com